

Coupe sur partie fixe

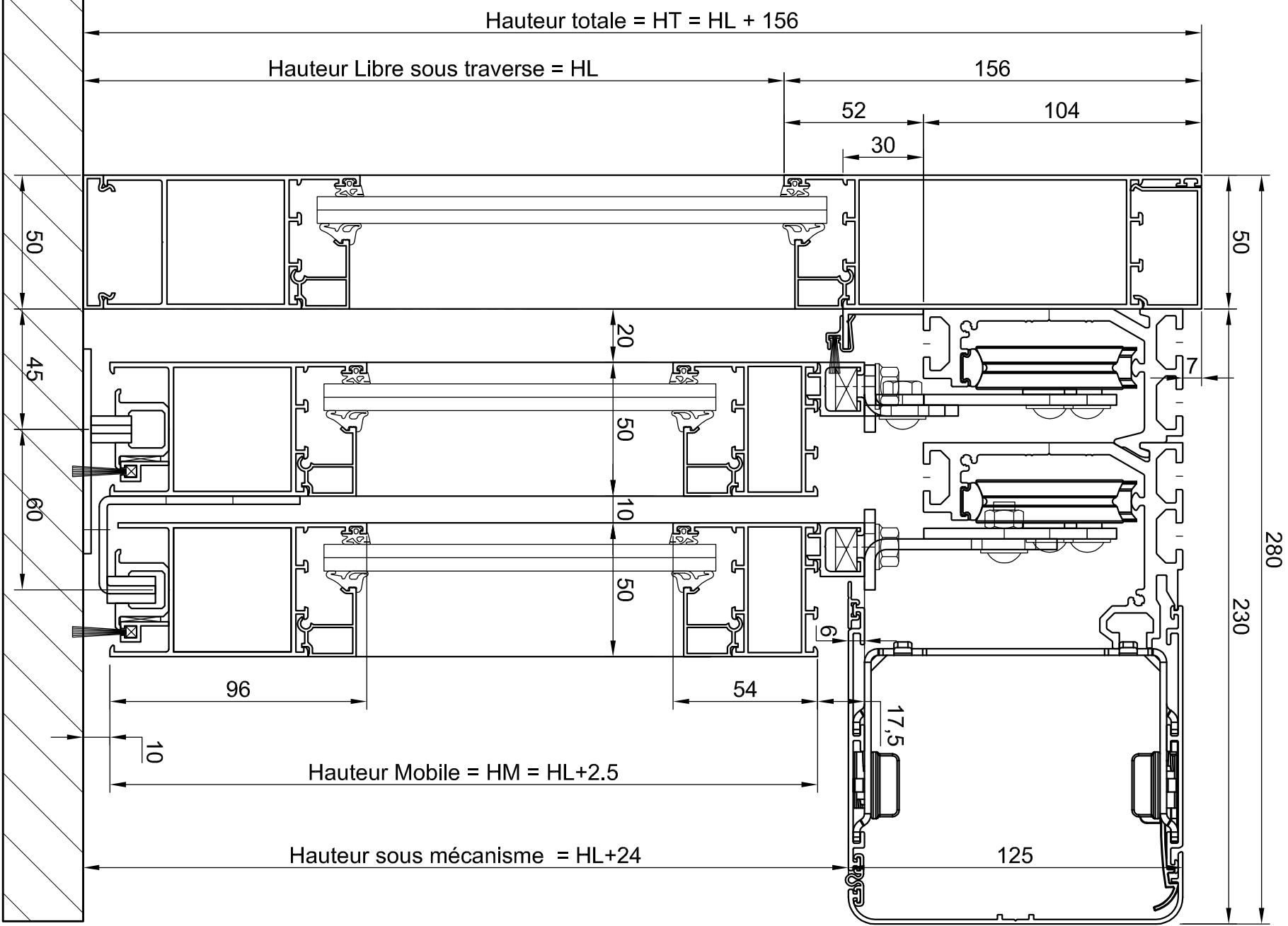

Coupe sur vantail lent

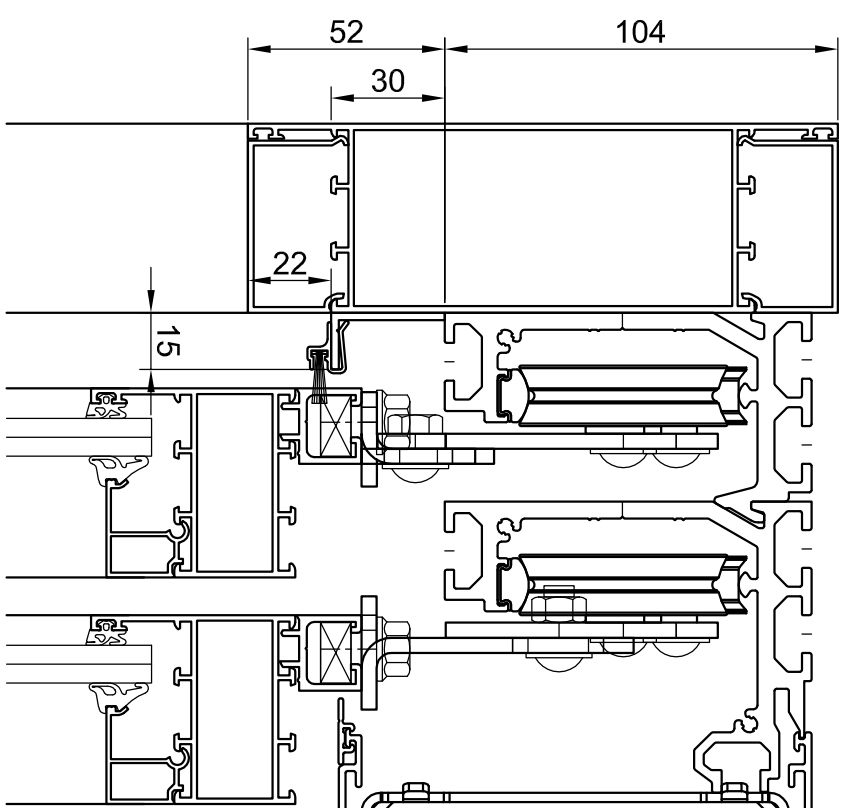

Coupe sur vantail Rapide

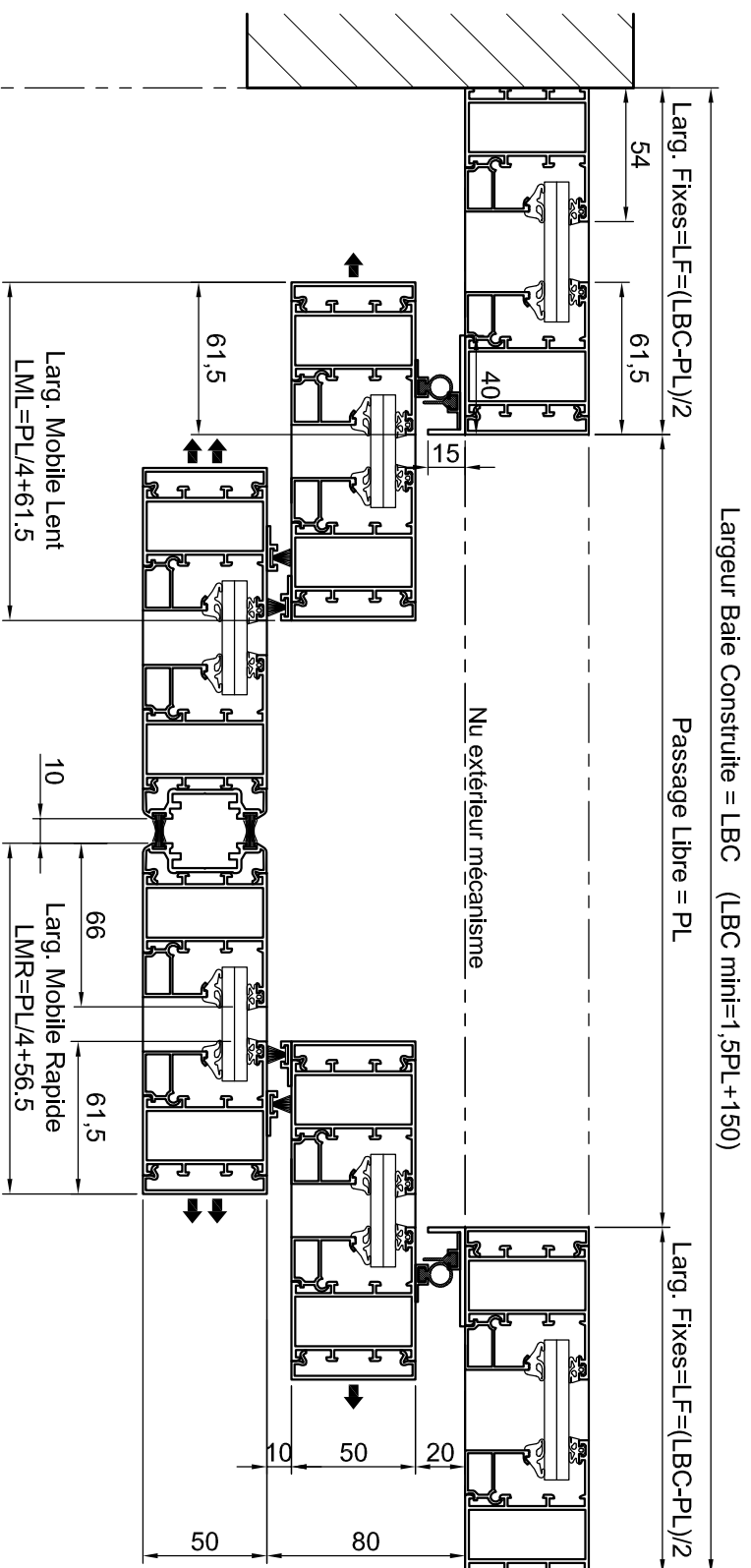
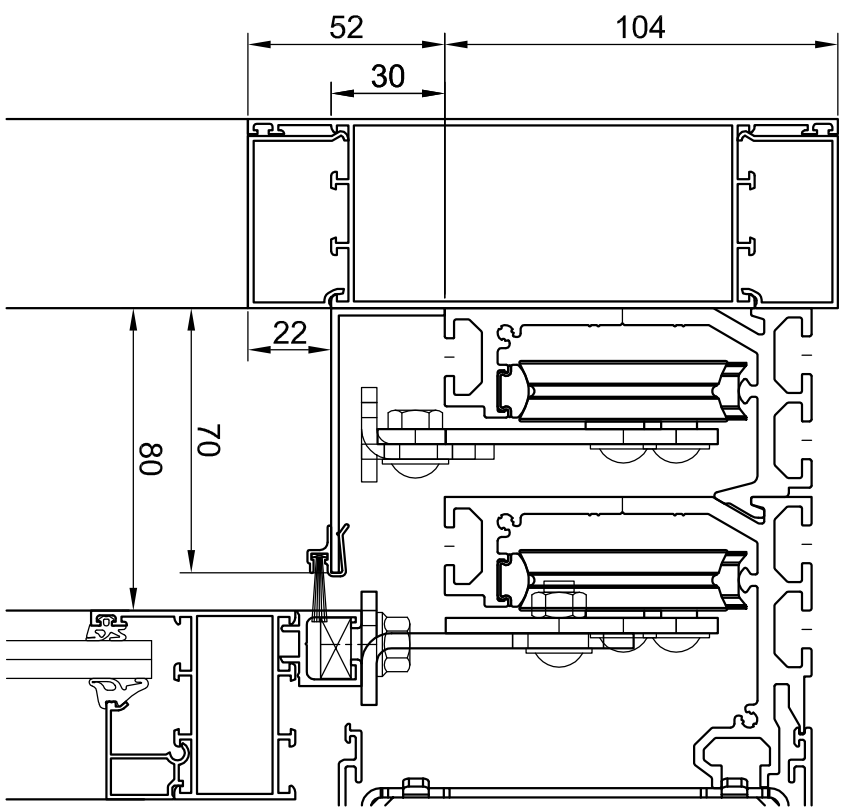

L' Larg. Baie Construite = LBC (LBC min = 1,5 PL + 150)



**manusa**  
Tél: 0479351500  
Fax: 0479615050

**VISIO - W50**  
**PA 4 Vantaux Téléscopiques + Fixes**

Format: A3 Ech:

Date: 01/10/2013

Ref: PTV5070-4VT+2F W50

Ind: