

Coupe sur partie fixe

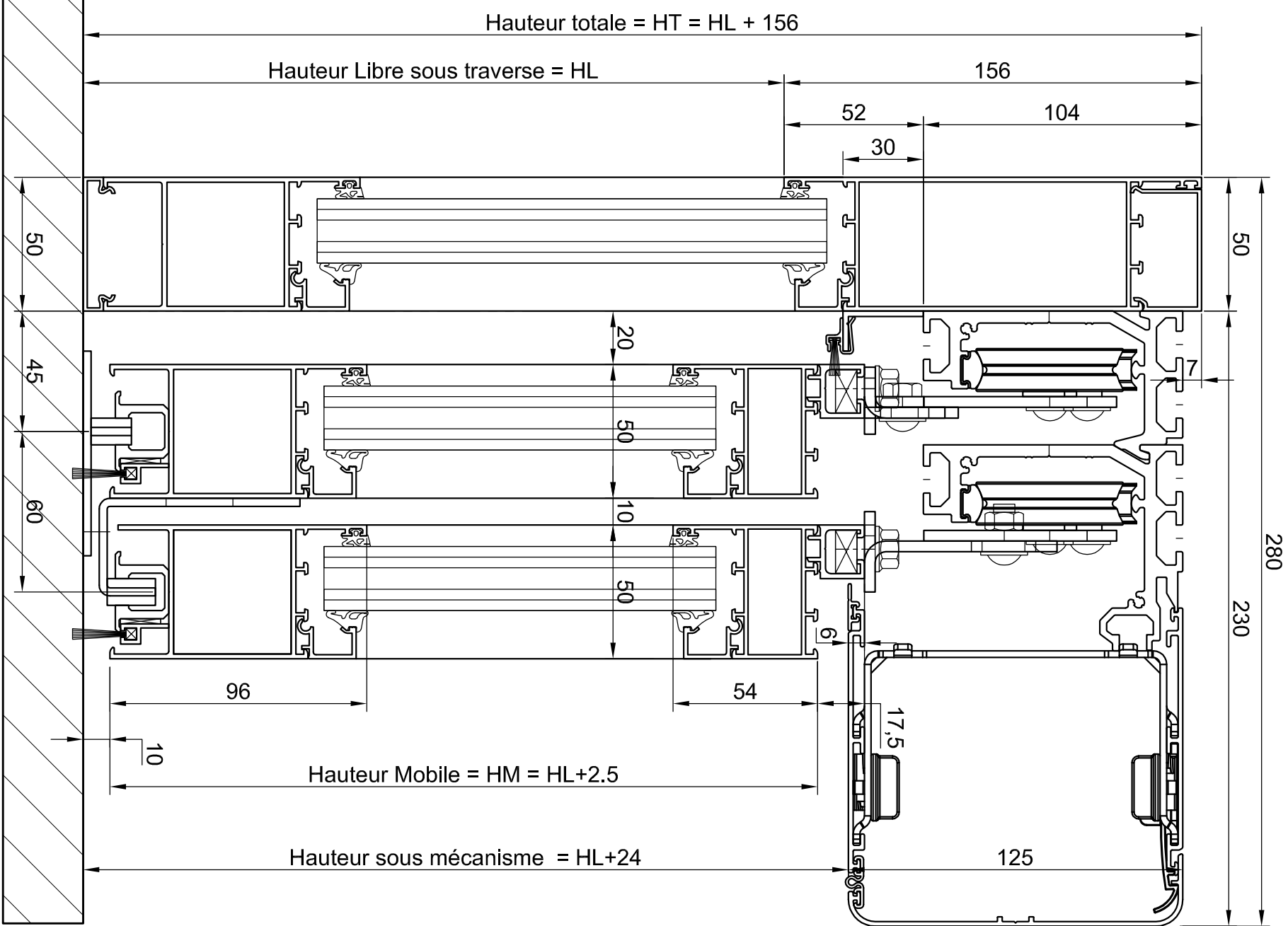

Coupe sur vantail lent

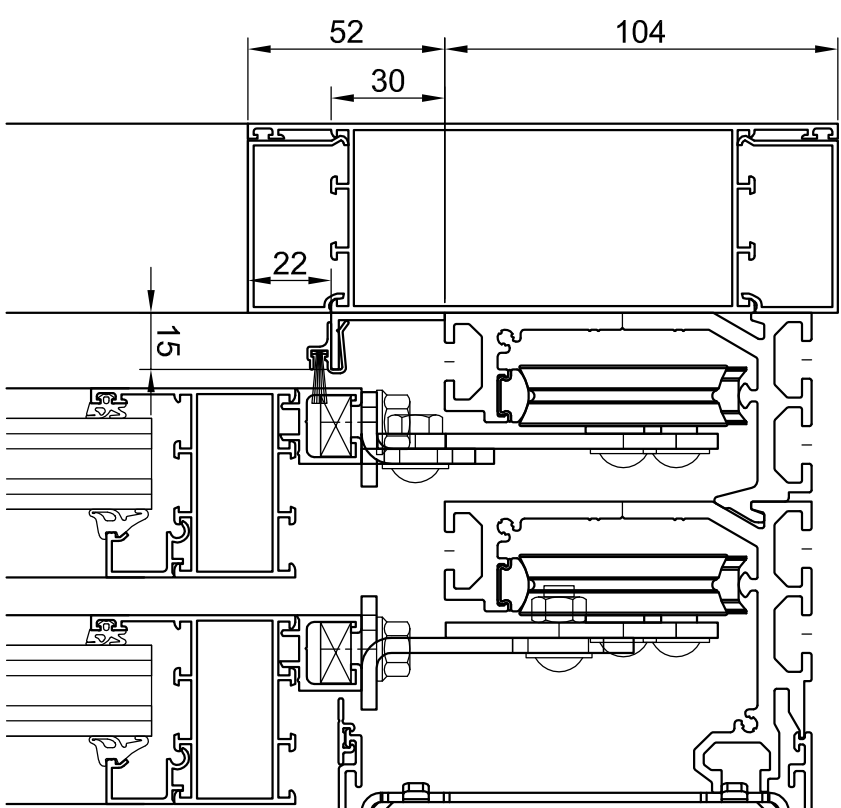

Coupe sur vantail Rapide

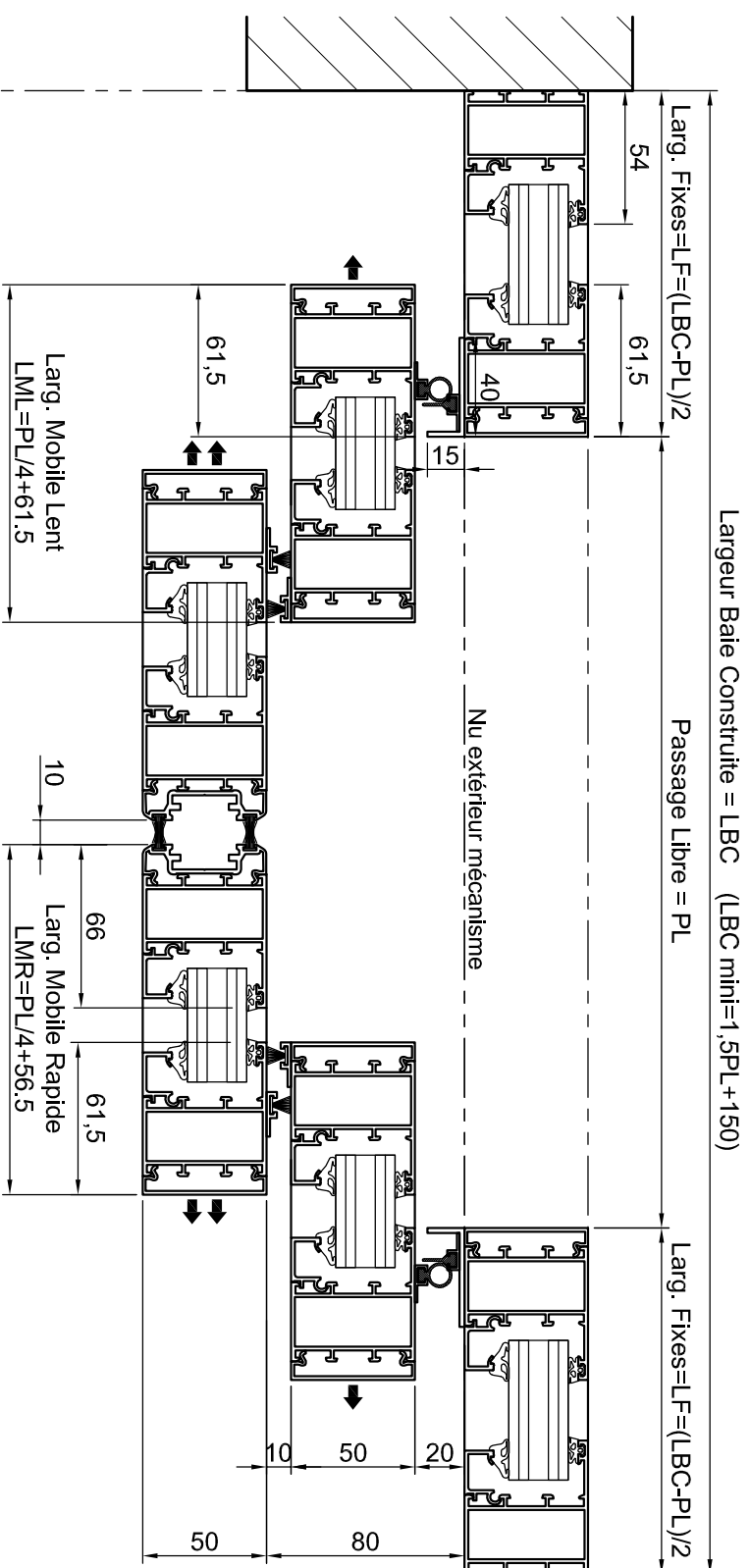
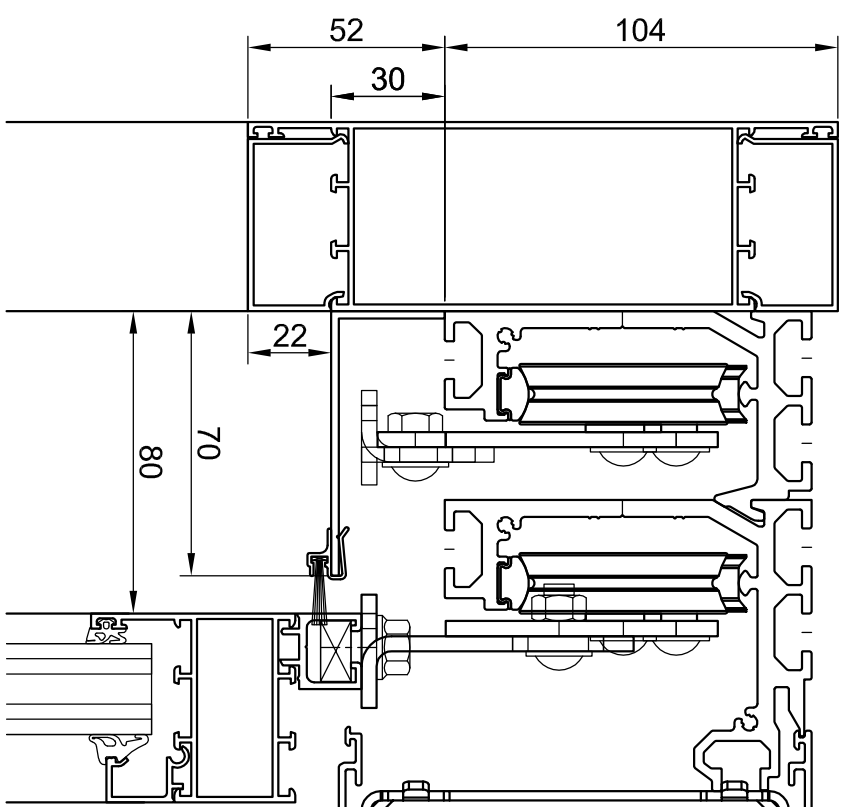

manusa

Tél: 0479351500
Fax: 0479615050

VISIO - W50

PA 4 Vantaux Téléscopiques + Fixes

Format: A3 Ech:

Date: 01/10/2013

Ref: PTV5070-4VT+2F W50+VI

Ind: